

OBIFOLD **BASIC PLUS** **BASIC PREMIUM**

*FOLDERS WITH MANY FOLDING
POSSIBILITIES AND
AUTOMATIC SORTING ABILITY*



OBIFOLD BASIC PLUS / BASIC PREMIUM

The OBIFOLD basic plus and basic premium are single lane folders for folding a wide range of pieces, like all kinds of terry towels, bath towels, kitchen towels, pillowcases, light garments and other flat pieces.

The OBIFOLD basic plus and basic premium folders are particularly suitable for a French primary fold (thirding), however a single primary midfold is also possible.

The primary fold is carried out by air blast. The pieces only stop for a shortest possible time. This makes it faster than comparable folders with mechanical folding blades.

The OBIFOLD basic plus and basic premium execute up to two crossfolds, which are made by reversing belts along with an airblast. Due to the wide crossfold section, a lot of different folding arts are possible.

After the folding process, the pieces will sorted and stacked on the dedicated stacker. Each piece with a unique length and width can have its own way of folding, consequently pre-sorting is not required.

The OBIFOLD basic plus is provided with 2 stackers (optionally 3), the OBIFOLD basic premium has 3 stackers (optionally 4).

A central conveyor belt for returning the stacks to the operator is included.

Within the OBIFOLD basic series a non sorting folder is also available.

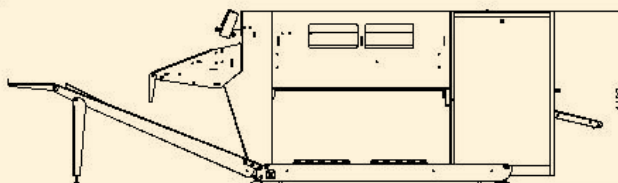
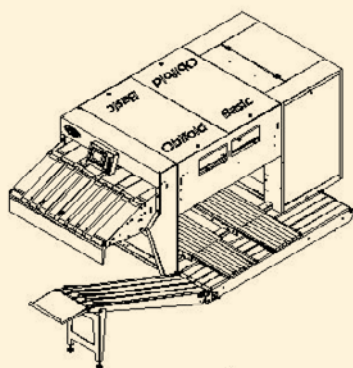

OBIFOLD Basic Plus

Machine specifications:

- French fold or midfold. Crossfolds can give an end-size of 1/2, 1/3 of 1/4 of the original length.
- High production capacity.
- A lot of different folding arts possible, due to wider crossfold section (500 mm / 20").
- Automatic sorting of pieces on 2 stackers.
- Automatic sorting of pieces on 3 stackers.
- Automatic sorting of pieces on 4 stackers.
- Flexible central conveyor configuration.
- PLC control system.
- Very operator friendly control panel with colour touchscreen.
- Easy adjustment of all kinds of program settings.
- Piece rejection button.
- Program and total counter.
- Enlarged primary fold for processing pieces up to 2400 mm (94") length.
- Wider stackers to accommodate large pieces (possibly in combination with enlarged primary fold).
- Intake conveyor belt with separate driver and photocell.
- Automatic stops for folding difficult pieces like fitted sheets.
- Frontplate underneath the intake conveyor for smooth intake of pieces.
- Sorting based on piece length.
- Sorting based on piece length and width.
- Display with clamb for instructions.
- Alternative power supply; 60Hz
- System diagnosis for easy problem solving.
- Ethernet capability
- Production control system with red/green light

Basic plus Basic premium

V	V
V	V
V	V
V	-
0	V
-	0
V	V
V	V
V	V
V	V
V	V
0	V
0	0
0	V
0	V
V	V
V	V
0	0
0	0
0	0
V	V
0	0
0	0
0	0

Technical specifications:

- Piece dimensions: max. 1800 x 1200 mm (71"x47").
- Piece dimensions: max. 2400 x 1200 mm (94"x47").
- Power supply: 3 x 380 V + 0 + earth, 50 Hz
- Power consumption: 1,2 kWh.
- Air consumption: 20-40 Nm³/1000 pieces.
- Air pressure: 6 – 10 bar.

V: standard feature

0: option

- : not available

